

**CSIR NET LIFE SCIENCE JUNE 2023 I**

**PART-A**

1. Mary and Mike are married to each other. John is Mary's brother while Douglas is Mike's brother. In a gathering of 2 children of Mary and Mike, 3 of John and 2 of Douglas, the number of first-cousin pairs (sibling's children are first-cousins to each other) is

1. 3
2. 6
3. 10
4. 21

2. A, B, C, D and E are members of a family. A is a doctor and wife of a lawyer. B is the brother of C and husband of a teacher. C is an engineer and daughter of the lawyer. Which of the following inferences can be definitely made?

1. D is the lawyer
2. E is the teacher
3. A is the wife of D
4. B is the son of A

3. A test consists of 20 questions and the students are awarded 4 marks for a correct answer, -1 mark for a wrong answer and 0 mark for an unattempted question. Which of the following could be a possible number of questions attempted by a student who secured 27 marks?

1. 15
2. 16
3. 17
4. 18

4. P starts a business with an investment of Rs. 30 lakh. Two months later Q joined with Rs.90 lakh. Subsequently R joined with Rs. 180 lakh. The year-end profit of Rs. 1.2 crore was distributed in proportion of the investment and duration in the partnership. If the profit received by R was Rs. 60 lakh, how many months after Q, did R join?

1. 3
2. 4
3. 5
4. 7

5. In a round-robin tournament (each team plays with all other teams once) between 8 teams, a win fetched 3 points and a draw, 1. After each team had played 4 matches, the total of the points of the teams was 34. The number of drawn games among those played till then was

1. 7
2. 2
3. 6
4. 14

6. If the difference between the two-digit numbers made from digits a and b is 27, the difference between a and b is

1. 2
2. 1
3. 4
4. 3

7. Choose the correct option that will make the following statement correct:  
THE NUMBER OF TIMES THE LETTER "I" OCCURS IN THIS SENTENCE IS \_\_\_\_\_.

1. FOUR
2. FIVE
3. SIX
4. SEVEN

8. Two cards are drawn together at random from a deck of 52 playing cards. What is the probability to get one red and one black card?

1.  $\frac{1}{2}$
2.  $\frac{13}{51}$
3.  $\frac{26}{51}$
4.  $\frac{26 \times 25}{52 \times 51}$

9. Which of the following correspond to x ,y and z, respectively in the following square where sum of elements in each column, row, and diagonal is the same?

16	11	x
17	y	13
z	19	14

1. (17, 15, 13)
2. (18, 15, 12)
3. (12, 15, 17)
4. (17, 16, 14)

10. Two cylindrical candles A and B are of the same height. The radius of A is twice that of B. If A takes 120 minutes to completely burn, how long does B take to burn half its initial height?

1. 60 min
2. 30 min
3. 15 min
4. 10 min

11. Three identical rings of radius 1 unit are stacked as shown in the figure. The length x is

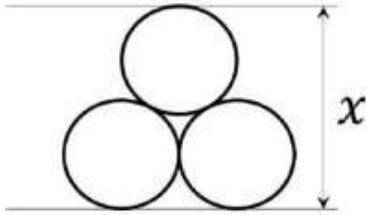

1.  $2 + \sqrt{3}$
  2.  $2 + \sqrt{2}$
  3.  $2 + 2\sqrt{\frac{2}{3}}$
  4. 3
12. If 6 students occupy a bench, one bench will be left completely unoccupied. If 5 students occupy each bench, instead, one student will not find a seat. The number of students is
1. 30
  2. 31
  3. 36
  4. 42
13. The possible number of integers between 1000 and 10000 containing two 2's, one 0 and one 3 (for example, 2023 is such an integer) is
1. 6
  2. 9
  3. 12
  4. 24
14. Four villages A, B, C and D are connected in that order by a circular road. A car traveling with a uniform speed covers the distance between A and B in 43 minutes, B and C in 23 minutes, C and D in 19 minutes and D and A in 47 minutes. Which of the following will be closest to the time (in minutes) taken to travel from A to C with the same speed along a straight road?
1. 42
  2. 66
  3. 45
  4. 21
15. A square paper is folded twice to a square shape one-fourth in area to the original square. Then equilateral triangles and circles are cut as shown in the figure.



Which one of the following is a possible pattern on the fully unfolded paper?

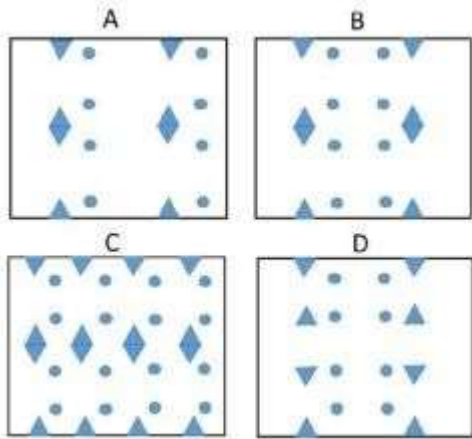

1. A
2. B
3. C
4. D

16. Which of the following is INCORRECT?

1.  $3^{\frac{1}{2}} + 3^{\frac{1}{2}} + 3^{\frac{1}{2}} = 3^{\frac{1}{2}} \times 3^{\frac{1}{2}} \times 3^{\frac{1}{2}}$
2.  $4^{\frac{1}{3}} + 4^{\frac{1}{3}} + 4^{\frac{1}{3}} + 4^{\frac{1}{3}} = 4^{\frac{1}{3}} \times 4^{\frac{1}{3}} \times 4^{\frac{1}{3}} \times 4^{\frac{1}{3}}$
3.  $5^{\frac{1}{4}} + 5^{\frac{1}{4}} + 5^{\frac{1}{4}} + 5^{\frac{1}{4}} + 5^{\frac{1}{4}} = 5^{\frac{1}{4}} \times 5^{\frac{1}{4}} \times 5^{\frac{1}{4}} \times 5^{\frac{1}{4}} \times 5^{\frac{1}{4}}$
4.  $6^{\frac{1}{6}} + 6^{\frac{1}{6}} + 6^{\frac{1}{6}} + 6^{\frac{1}{6}} + 6^{\frac{1}{6}} + 6^{\frac{1}{6}} = 6^{\frac{1}{6}} \times 6^{\frac{1}{6}} \times 6^{\frac{1}{6}} \times 6^{\frac{1}{6}} \times 6^{\frac{1}{6}} \times 6^{\frac{1}{6}}$

17. Given graph depicts the data of people going to gym and deaths per year in different cities. Which of the following can be definitely concluded from the graph?

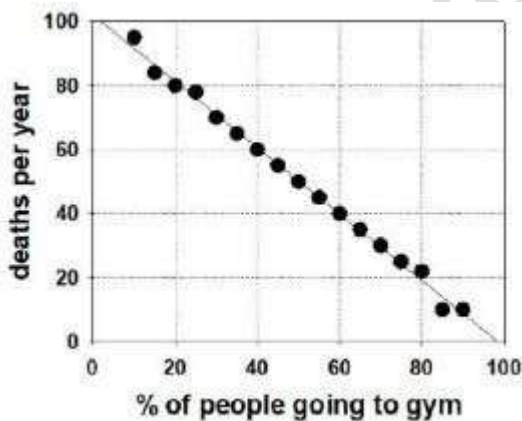

1. Gym makes people fit and improves their health.
2. None will die if all go to gym.
3. Gym helps people to save their lives in cities.
4. In the city where on the average 50% people go to gym, 50 people die per year.

18. ABCD is a square. EFGH is a rectangle inscribed within the square with its sides parallel to the diagonal AC of the square. The perimeter of the rectangle EFGH is 16. The side of the square is

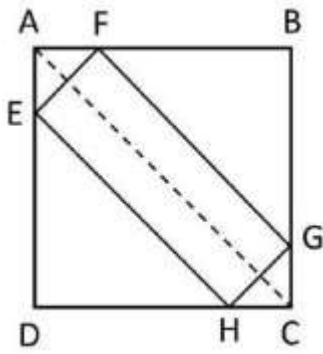

1.  $\frac{8}{\sqrt{2}}$
2. 8
3. 4
4.  $8\sqrt{2}$

19. Suppose  $(729)^{\frac{22}{3}}(81)^{\frac{x}{2}} = 3$ . The value of x is

1. -21
2. -21.5
3. -22
4. -20.5

20. A and B are circles of unit radius. Their centres are marked by X. The area of the shaded region is (hint: area of an equilateral triangle of unit side length is  $\frac{\sqrt{3}}{4}$ )

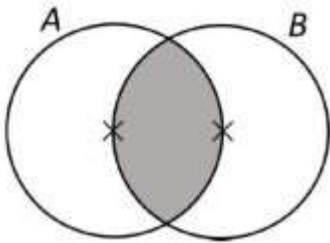

1.  $\frac{2\pi}{3} - \frac{\sqrt{3}}{2}$
2.  $(\frac{2\sqrt{3}}{4} + \pi)$
3.  $\frac{2\pi}{3} + \frac{\sqrt{3}}{2}$
4.  $\frac{2\pi}{3} - \frac{\sqrt{3}}{4}$

#### PART-B

1. Recessive lethal alleles are never completely eliminated from the population because:

1. lethal alleles are always conditional in nature.
2. lethal alleles have selective advantage.
3. they are maintained in the population as heterozygotes.
4. lethal alleles protect organisms from other deleterious mutations.

2. In the context of protein import in the nucleus, which molecule is responsible for releasing the cargo from the importing receptor?

1. Ras
2. RhoA
3. Ran
4. Rock

3. Which one of the following mammalian species is distributed in evergreen forests?

1. Nilgai
2. Black buck
3. Cheetah
4. Lion-tailed macaque

4. Which one of the following root initials gives rise to the root vascular system, including the pericycle?

1. Columella initials
2. Epidermal-lateral root cap initials
3. Cortical-endodermal initials
4. Stele initials

5. In mature erythrocytes, the end-product of glycolysis that contains the carbons of glucose is:

1. ethanol
2. pyruvate
3. acetaldehyde
4. lactate

6. Segregation of alleles can occur either at anaphase I or anaphase II of meiosis. Which one of the following is an ideal model system for identifying the stage at which allelic segregation occurred?

1. *Arabidopsis thaliana*
2. *Drosophila melanogaster*
3. *Neurospora crassa*
4. *Saccharomyces cerevisiae*

7. The mode of action of cholera toxin in causing diarrhoea is by:

1. inactivating  $G_i$  protein.
2. continuous activation of adenylyl cyclase.
3. locking  $G_s$  protein in an inactive state.
4. rapidly hydrolyzing GTP to GDP.

8. The hemolysis of red blood cells takes place when they are suspended in which one of the following solutions?

1. 2.0% NaCl
2. 1.5% NaCl
3. 1.0% NaCl
4. 0.5% NaCl

9. Which one of the following statements about LINES present in the human genome is TRUE?

1. LINES preferentially localize to AT-rich DNA.
2. LINES cannot transpose independently.
3. By parasitizing on the SINE element transposition machinery, LINES can attain very high copy number.
4. The Alu family is the most prominent LINE family in terms of copy number.

10. The following terms represent different methods in phylogenetic tree constructions.

- A. Unweighted Pair Group Method Using Arithmetic Average (UPGMA)
- B. Minimum Evolution (ME) method
- C. Maximum Parsimony (MP) method
- D. Maximum Likelihood (ML) method

Select the option that represents all distance-based methods?

1. A and B
2. B and C
3. C and D
4. A and D

11. During glycolysis in plants, alanine and related amino acids are directly produced from which one of the following precursors?

1. 3-Phosphoglycerate
2. Phosphoenolpyruvate
3. Pyruvate
4. Acetyl-CoA

12. Which of the following statements about site-specific recombinases is NOT true?

1. The Cre recombinase is believed to mediate the circularization of the P1 phage genome during infection of the bacterial host.
2. The  $\lambda$  integrase cannot mediate integration of the  $\lambda$  genome into the host genome without the help of accessory proteins.
3. The Hin invertase-mediated recombination event is stimulated by protein-DNA interactions at a 60 bp enhancer sequence.
4. In Xer recombinase-mediated monomerization of chromosomal dimers, the interaction of FtsK with XerCD activates XerC and initiates the re-combination process.

13. Which one of the following is correct regarding zeitgebers?

1. Have no effect on biological rhythms
2. Sense biological rhythms
3. Synchronize biological rhythms
4. Abolish biological rhythms

14. Which one of the following statements is INCORRECT?

1. Avr proteins predominantly have SecA secretion signals.
2. Avr proteins are secreted through the type III secretion system (T3SS).

3. Hypersensitive response and pathogenicity (HRP) cluster proteins are involved in the secretion of Avr proteins.
4. Some of the components of the T3SS pathway are conserved between animal- and plant-pathogenic bacteria.

15. Which one of the following sugars will not reduce Tollen's reagent?

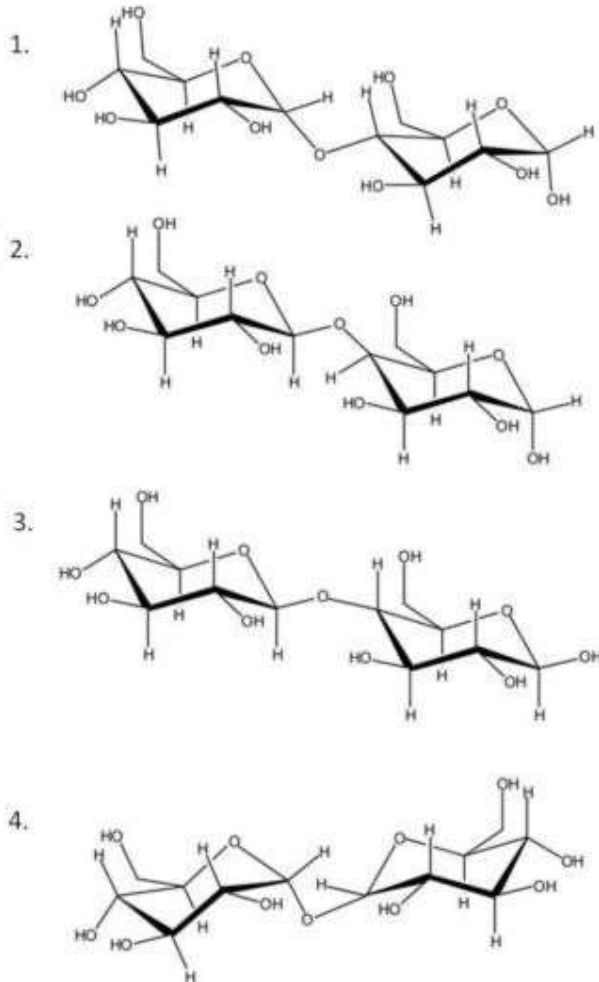

16. Which one of the following is the communicating junction linking adjacent cells in plants, which permits small molecules to pass from cell to cell while blocking the passage of most large molecules?

1. Adherens junction
2. Gap junction
3. Plasmodesmata
4. Hemidesmosome

17. Which one of the following mRNAs is most likely to be exported out of the nucleus?

1. Spliced RNA associated with the poly A binding and cap binding complex.
2. Mis-spliced RNA with multiple stop codons, for degradation in cytosol.
3. Spliced RNA with the associated spliceosomal complex.
4. Uncapped and unspliced RNA.



18. Which one of the following species of birds is known to migrate across the Himalayas?
1. Sarus Crane
  2. Red-vented Bulbul
  3. Jacobin Cuckoo
  4. Bar-headed Goose
19. The solubility of  $NaCl$  is greater in water than ethanol. What physical property of the solvent governs this difference?
1. Surface tension
  2. Viscosity
  3. Dielectric constant
  4. Boiling point
20. Which one of the following statements regarding molecular markers for genotyping is INCORRECT?
1. Polymorphism in intronic regions of a gene cannot be used for trait mapping.
  2. Codominant molecular markers can be used to detect heterozygosity.
  3. Sequence Tagged Microsatellite Sites (STMS) and Simple Sequence Repeat Polymorphisms (SSRPs) are based on polymorphisms in repetitive DNA sequences.
  4. Restriction Fragment Length Polymorphisms (RFLPs) and Simple Sequence Repeats (SSRS) are multi-allelic markers.
21. Which one of the following types of promoters would NOT be used within the T-DNA for expression of a negative selection marker gene for generation of transgenic plants by *Agrobacterium*-mediated transformation?
1. strong constitutive promoter
  2. tissue-specific promoter
  3. substrate-inducible promoter
  4. stress-inducible promoter
22. The grizzled giant squirrel, *Ratufa macroura*, naturally occurs in
1. north-east India and Burma
  2. western Himalayas
  3. southern India and Sri Lanka
  4. Andaman and Nicobar islands
23. The non-ciliated cuboidal epithelial cells in bronchioles that secrete important defense markers are called
1. Goblet cells
  2. Basal cells
  3. Langerhans cells
  4. Club cells
24. The flowers of which one of the following plant species is used by indigenous communities of Central India to make an intoxicant for consumption?
1. Mahua (*Madhuca* spp.)

2. Monkey-puzzle tree (*Araucaria* spp.)
3. Rhododendron (*Rhododendron* spp.)
4. Elephant grass (*Pennisetum* spp.)

25. Clonogenic neoblasts are involved in planarian (flatworm) regeneration. This is an example of:

1. epimorphosis
2. morphallaxis
3. stem cell-mediated regeneration
4. compensatory regeneration

26. Based on the image given below, select the option that describes it correctly:

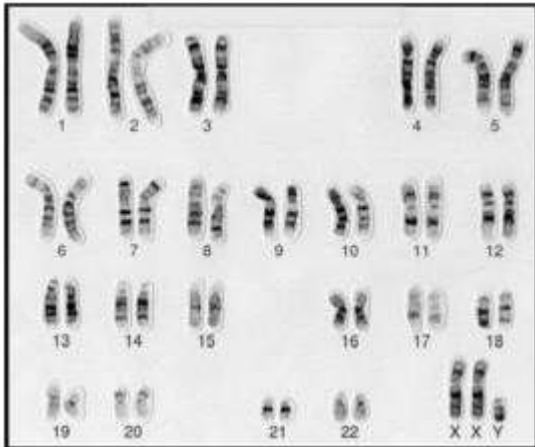

1. Q-banded normal human karyotype.
2. G-banded human karyotype depicting aneuploidy.
3. C-banded karyotype depicting Klinefelter syndrome.
4. G-banded normal human karyotype.

27. Which one of the following changes is energetically favorable and occurs spontaneously in an aqueous solution?

1. Formation of a bilayer from phospholipid molecules
2. Dispersion of one oil droplet into many small ones
3. Tearing of the lipid bilayer
4. Conversion of a membrane vesicle to a flat bilayer

28. A patient was injected with Purified Protein Derivative (PPD) to diagnose TB disease or a previous exposure to *Mycobacterium tuberculosis*. The injected area, when inspected after 48-72 hours was found to develop induration (thick, hardened bulge). Which of the following cells will be predominant at this site?

1. Neutrophils and mast cells
2. Helper T cells and macrophages
3. Eosinophils and mast cells
4. Natural killer and dendritic cells

29. Which one of the following methods is best suited to estimate the population size of fish?

1. Camera Trap
2. Line Transect
3. Point count
4. Mark-Recapture

30. Which one of the following statements regarding PEPCase is INCORRECT?

1. During the day, C4 PEPCase is inactive whereas CAM PEPCase is active.
2. PEPCase is inactivated by dephosphorylation.
3. PEPCase kinase phosphorylates PEPCase.
4. The synthesis of PEPCase kinase is modulated by circadian rhythm in CAM leaves.

31. Which one of the following codons is used to code for selenocysteine in Escherichia coli?

1. UGA
2. UAA
3. UAG
4. UCC

32. Which one of the following plant-derived molecules is widely used as an analgesic?

1. Abscisic acid
2. Salicylic acid
3. Jasmonic acid
4. Gibberellic acid

33. Which one of the following characteristics is NOT correct for bryophytes?

1. All bryophytes are homosporous.
2. Gametophyte is the dominant phase of the life cycle.
3. The antherozoids are always biflagellate.
4. Water is conducted by hydroids in all bryophytes.

34. Directional Selection for a particular trait will lead to the frequency of the trait:

1. being normally distributed in the population.
2. always showing a left-skewed distribution in the population.
3. always showing a right-skewed distribution in the population.
4. showing either a right- or a left-skewed distribution in the population.

35. Which one of the following terms is used for species that exploit the same resources in a similar manner?

1. Guild
2. Taxonomic order
3. Community
4. Assemblage

36. A temperature sensitive *S. pombe* mutant exhibits cell cycle arrest both, at the G1 to S, as well as at the G2 to M transition phases. This is possibly a mutant of:

1. Clb1
2. Cyclin B
3. Cdc2 only
4. Cdc2 and Clb3

37. Which one of the following translation factors is used at the step of translation initiation and defined as anti-association factor for 30S and 50S subunit interactions?

1. IF1
2. IF2
3. IF3
4. RRF

38. Which one of the following factors inhibits renin secretion?

1. Increased level of plasma catecholamines.
2. Increased blood pressure in the afferent arterioles leading to glomerulus.
3. Increased activity of sympathetic nerves connected to kidney.
4. Prostaglandins.

39. The extracellular domain of a cell surface receptor (A) was switched with the extracellular domain of another receptor (B) to create a chimeric receptor (B-A). Assuming that there is no effect on the functionality of the domains in the chimeric receptor, what is the most likely outcome in the presence of the ligand for receptor B?

1. The ligand will activate the pathway normally triggered by receptor A.
2. The ligand will activate the pathway normally triggered by receptor B.
3. The chimeric receptor will fail to transduce any signal in response to the ligand.
4. The chimeric receptor will cause constitutive activation of the signalling pathway.

40. A positive association between absolute average individual fitness and population size over some finite interval is known as

1. Allee effect
2. Founder effect
3. Rensch's rule
4. Bergmann's rule

41. Given that Asian Koel is a brood parasite, which one of the following statements is TRUE for this species?

1. The brood of the bird is usually infested with parasitic wasps.
2. The young ones learn the calls of their foster parents.
3. The bird feeds parasitic wasps to its brood.
4. The call of the species is innate and not learned.

42. Homeotic selector genes are responsible for the specification of Drosophila body parts. Which one of the following identities would you expect if the ultrabithorax gene is deleted?

1. The third thoracic segment is transformed to another second thoracic segment and a fly with four wings.

2. The third thoracic segment develops halteres.
  3. The second thoracic segment loses wings.
  4. The first and second thoracic segments fuse and wings are formed on the third thoracic segment.
43. Invasive species, in general grow very well in a new area that they invade, and often outcompete native species. An explanation for the better growth and propagation of invasive species in comparison to their native counterparts is provided by which one of the following hypotheses?
1. Ecological niche hypothesis
  2. Intermediate disturbance hypothesis
  3. Enemy release hypothesis
  4. Biotic resistance hypothesis
44. Which one of the following statements is correct for a primary successional species?
1. These species do not follow specific survivorship curves.
  2. These species show Type II survivorship curve.
  3. These species show Type III survivorship curve.
  4. These species show Type I survivorship curve.
45. Appressorium is expected to be formed during which one of the following diseases?
1. Bacterial leaf blight in rice
  2. Bacterial wilt in tomato
  3. Powdery mildew in pea
  4. Leaf curl disease in tobacco
46. Which one of the following factors will NOT have any impact on the resolving power of a bright field microscope?
1. Color of light
  2. Intensity of light
  3. Angle of admittance of light in the objective lens
  4. Medium between the objective lens and specimen
47. Which one of the following describes an amphisome?
1. It is an intermediate/hybrid organelle produced through the fusion of endosomes with autophagosomes within cells.
  2. It is a double-membrane sequestering vesicle that is the hallmark of the intracellular catabolic process called macroautophagy.
  3. It is a compartment formed when autophagosome fuses with a lysosome.
  4. It is a vacuole that arises when membranes of the ER sequester parts of the cytoplasm.
48. The standard free energy ( $kJ\ mol^{-1}$ ) of hydrolysis of glucose-1-phosphate is:
1.  $-40.3$
  2.  $-35.8$
  3.  $-7.7$
  4.  $-20.9$

49. Consider alleles 'A' and 'a' in a population. The frequency of heterozygotes will be highest when:

1. Frequency of 'A' is more than frequency of 'a'
2. Frequency of 'A' is less than frequency of 'a'
3. Frequency of 'A' is equal to frequency of 'a'
4. Frequency of 'A' and 'a' affects the frequency of homozygotes, not heterozygotes

50. Given below are characteristic traits found in sun- or shade-acclimated leaves

- A. High dry mass per unit area
- B. Higher number of chloroplasts per area
- C. Lower Chl-a/Chl-b ratio
- D. Lower dark respiration per area
- E. Higher light harvesting complexes per area

Select the option that has all correct characteristics for shade-acclimated leaves?

1. A, B and C
2. C, D and E
3. A, C and D
4. B, C and D

#### PART-C

1. The following statements are made regarding the amphibian early-embryonic development:

- A. The Nieuwkoop center cells are mesodermal in origin.
- B. Chordin, Noggin and Goosecoid are secreted by the Organizer.
- C. The default fate of the ectoderm is to become neural tissue.
- D. BMP levels are high in the presumptive dorsal mesoderm.

Which one of the following options represents the combination of all correct statements?

1. A, B and C
2. C and D
3. B and C only
4. A and D

2. Four different plant communities that consisted of the same number of species were taken up for a species diversity study. The following table represents some of the outcomes:

Community	Simpson's Reciprocal Index Value
A	7.25
B	8.20
C	6.80
D	7.05

Select the correct statement about the evenness of the above communities.

1. The evenness of all the four communities is the same.
2.  $B > A > D > C$  represents the decreasing order in evenness of the communities.
3.  $C > D > A > B$  represents the decreasing order in evenness of the communities.
4. Using the given information, we cannot compare the evenness of the communities.

3. Members of the chlorophytes are structurally diverse. Select the option that correctly represents the increasing order of structural complexity among the given genera.

1. *Chlorella* < *Zygnema* < *Oedogonium* < *Draparnaldia*
2. *Volvox* < *Chara* < *Oedogonium* < *Draparnaldia*
3. *Chlorella* < *Draparnaldia* < *Fritschiella* < *Oedogonium*
4. *Volvox* < *Ulothrix* < *Draparnaldia* < *Ulva*

4. The following statements are made with reference to the neural connections of cardiac tissues and the functions of these nerves on heart in adult humans:

- A. The right vagus nerve is distributed mainly to the AV node.
- B. The parasympathetic pre-ganglionic fibers distributed to the heart originate from the superior salivatory nucleus.
- C. The sympathetic post-ganglionic fibers originating from the paravertebral ganglia of the left side primarily innervate SA node.
- D. The sympathetic fibers distributed to heart come mainly from stellate ganglia.
- E. The sympathetic activity alters heart rate slower than that of vagal activity.

Which one of the following options represents the combination of all correct statements?

1. A and B
2. B and C
3. C and D
4. D and E

5. Sucrose-phosphate synthase (SPS) and sucrose-phosphate phosphatase (SPP) are two key enzymes involved in the biosynthesis of sucrose. Following are certain statements regarding these two enzymes:

- A. Fructose-6-phosphate is one of the substrates of SPS enzyme.
- B. Fructose-6-phosphate and UDP-glucose are the substrates of SPP enzyme.
- C. Sucrose is the final product of SPP enzyme.
- D. UDP is one of the products of SPS enzyme while Pi is one of the products of SPP enzyme.

Which one of the following options represents the combination of all correct statements?

1. A, B and C
2. A, B and D
3. A, C and D
4. B, C and D

6. T4 phages were plated on three *E. coli* bacterial plates labelled I, II and III. The phenotypes obtained are depicted in the picture below. The black spots represent plaques.

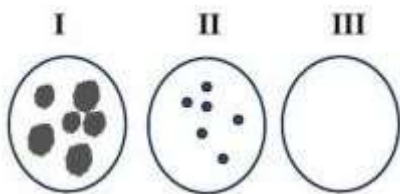

The following combination of conditions were given to explain the results obtained:

Plate	Bacterial strain	<i>rII</i> locus
I	i. either B or K-12	a. Wild type
II	ii. B	b. mutant
III	iii. K-12	

From the options listed below, select the one that accurately lists the *E. coli* strain type and the corresponding *r/l* locus type.

1. I-iii-a, II-ii-b, III-iii-a
2. I-ii-b, II-i-a, III-iii-b
3. I-i-b, II-iii-b, III-ii-a
4. I-ii-b, II-ii-a, III-ii-b

7. Following statements were made regarding regeneration in different organisms:

- A. The regenerating blastema cells in amphibians retain their specification even when they dedifferentiate.
- B. A transgenic Hydra when made to misexpress  $\beta$ -catenin will show numerous ectopic tentacles.
- C. In Planaria, if the Wnt pathway is activated, then the posterior blastema would regenerate a head.
- D. A regenerating blastema is formed in the mammalian liver.

Which one of the following options represents all correct statement(s)?

1. A only
2. C only
3. B and C
4. C and D

8. A food chain involving *Spartina* (a plant), the marsh periwinkle snail, the blue crab and an unknown fungus was identified in a *Spartina*-dominated salt marsh in North America. A study involving control and crab-exclusion experiments revealed:

- A. Radulations (scrape marks) on the leaf surface made by the snails indicate the presence of snail faeces, fungi and dead plant tissue.
- B. The fungi were present only at the radulations.
- C. The density of the radulations increased with higher snail densities.
- D. *Spartina* density decreased with increase in the snail density till it reached zero.
- E. In control experiments, all four species were present till the end.

Select the option that correctly depicts the positive (+) and negative (–) interaction-type between fungi-snail and *Spartina*-crab, respectively:

1. – and +
2. – and –
3. + and –
4. + and +

9. The following trees represent different evolutionary mechanisms.



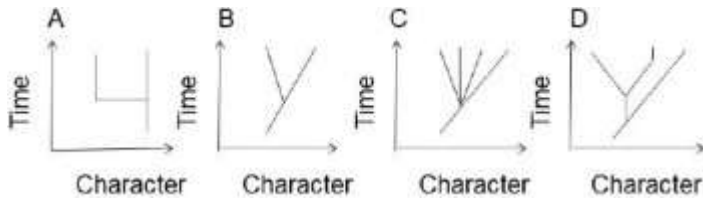





Select the tree that best represents punctuated equilibrium.

1. A
2. B
3. C
4. D

10. In four taxa (A, B, C and D), two characters (shape and color) were scored to infer their phylogenetic relationship. The two character states for shape were square and round, while the two character states for color were black and yellow. The character distribution is given in the table below.

TAXON	CHARACTERS	
	SHAPE	COLOUR
M		BLACK
N		YELLOW
O		YELLOW
P		YELLOW

Using the above data, four trees were built using the method of maximum parsimony which are given below.

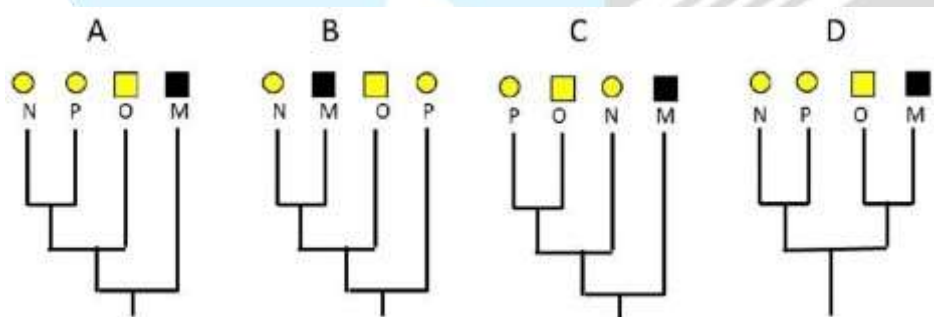

Select the option that represents the two most parsimonious trees.

1. A and B
2. C and D
3. B and C
4. A and D

11. In many sexually reproducing organisms, females make mate choice decisions based on male display traits. Several models have been proposed to explain the evolution of exaggeration in male traits. Two of them have been given below in column P and their possible descriptions in column Q.

Column P	Column Q
A. Runaway Selection	i. Males exploit a pre-existing sensory bias in females. Females choosing such males have higher quality offspring.
	ii. Female choice for male trait occurs due to perceptual errors leading to poor quality offspring. Thus, females will evolve to run away from males with such traits.
B. Chase-away selection	iii. Female choice for male trait results in a positive feedback loop favouring both, males with such trait and females that prefer them.
	iv. Males exploit pre-existing sensory bias in females. Females do not benefit by choosing such males, driving the evolution of females that discriminate against such males.

Match the models to their appropriate description and choose the correct option.

1. A-i; B-ii
2. A-ii; B-iii
3. A-iii; B-iv
4. A-iv; B-i

12. Given below are terms related to various techniques (Column X) and their features (Column Y):

Column X	Column Y
Techniques	Features
A. Reverse transcription	(i) Detection of clones encoding nucleic acid binding proteins
B. Southwestern blotting	(ii) Determination of 5' and 3' DNA sequences flanking a known gene
C. Genome walking PCR	(iii) Cloning of cDNA ends
D. RACE	(iv) cDNA library

Which one of the following options represents all correct matches between Column X and Column Y?

1. A-iv, B-i, C-ii, D-iii
2. A-iii, B-iv, C-i, D-ii
3. A-ii, B-iii, C-iv, D-i
4. A-iv, B-i, C-iii, D-ii

13. Some ligands/stimuli that operate through G protein-coupled receptors (GPCRs) are listed in column X, and the most common effectors through which they act are listed in column Y.

Column X	Column Y
Ligands/stimuli	Effectors
A. Serotonin	i. Phospholipase C
B. Acetylcholine	ii. cGMP phosphodiesterase

C. IgE-antigen complexes	iii. Adenylyl cyclase
D. Light	iv. Potassium channel/Adenylyl cyclase

Which one of the following options represents all correct matches between Column X and Column Y?

1. A- i; B-ii; - iii; D- iv
2. A- ii; B- iii; C- iv; D-i
3. A- iii; B- iv; C- i; D- ii
4. A- iv; B- i; C- ii: D- iii

14. The cycling of monomeric G proteins, such as Ras, between active and inactive states is aided by accessory proteins that bind to the G protein and regulate its activity. These accessory proteins include GTPase-activating proteins (GAPs) and guanine nucleotide-exchange factors (GEFS). The following conditions refer to different states of GAP and GEF proteins:

- A. A non-functional GAP
- B. A permanently activated GAP
- C. A non-functional GEF
- D. A permanently activated GEF

Which one of the following options represents conditions/states that might cause a constantly activated signaling cascade?

1. A and B
2. B and C
3. C and D
4. A and D

15. Given below are the list of abiotic environmental factors (Column X) and their primary effects (Column Y) in plants:

Column X	Column Y
Factors	Effects
A. Water deficit	(i) Ion cytotoxicity
B. Salinity	(ii) Hypoxia to the roots
C. Flooding	(iii) Photoinhibition
D. High light intensity	(iv) Water potential reduction

Which one of the following options represents all correct matches?

1. A (i), B (ii), C (iii), D (iv)
2. A (iv), B (i), C (ii), D (iii)
3. A (ii), B (i), C (iv), D (iii)
4. A (iv), B (iii), C (ii), D (i)

16. Which one of the following options correctly lists ecosystems of the world arranged according to the descending order of their average world net primary production (billion *kcal/yr*)?

1. Tropical rain forests>Northern coniferous forests Open Oceans> Estuaries
2. Open Oceans> Tropical rain forests> Northern coniferous forests>Estuaries
3. Tropical rain forests Open Oceans>Northern coniferous forests> Estuaries
4. Open Oceans> Northern rain forests Estuaries> Northern coniferous forests

17. The following statements are made about the E. coli SOS response to DNA damage:

- A. RecA-DNA filament complex stimulates the autoproteolytic activity of the LexA repressor.
- B. RecA is activated due to the blunt ends of double-strand breaks caused by DNA damage-inducing agents.
- C. The SOS response includes the activation of synthesis of translesion polymerases.
- D. The destruction of LexA promotes synthesis of photolyase, which acts along with RecA to reverse the pyrimidine dimer formation process.

Which one of the following options represents the combination of all correct statements?

- 1. A and D
- 2. B and D
- 3. A and C
- 4. C and D

18. Which one of the following statements is correct in the context of erythromycin-mediated inhibition of protein synthesis in bacteria?

- 1. Erythromycin inhibits protein synthesis at the step of elongation, but it nonetheless allows translation of the first few codons.
- 2. Erythromycin inhibits protein synthesis at the step of elongation, and it prevents formation of even the first peptide bond.
- 3. Erythromycin inhibits formation of the translation initiation complex.
- 4. Erythromycin is toxic to bacteria because it results in initiation of protein synthesis with elongator tRNAs.

19. India has designated regions as sanctuaries or national parks (column Q) dedicated for the conservation of specific species (column P).

Column P	Column Q
A. Gharial	i. Bhitarkanika Wildlife Sanctuary
B. Saltwater Crocodile	ii. National Chambal Sanctuary
C. Humpback Mahseer	iii. Gahirmatha Sanctuary
D. Hawksbill turtle	iv. Cauvery Wildlife Sanctuary

Select the option that depicts all correct matches between column P and column Q.

- 1. A-ii; B-i; C-iv; D-iii
- 2. A- iii; B- iv; C-i; D-ii
- 3. A-iv; B-iii; C-ii; D-i
- 4. A-ii; B-iv; C- i; D-iii

20. What is the pH of a  $10^{-7}$  M solution of *HCl*?

- 1. 6.00
- 2. 6.79
- 3. 7.00
- 4. 7.50

21. Alleles A, a, B and b can be distinguished on the basis of their mobility on an agarose gel. These genes are present on the same chromosome. In the gel image below, the band pattern reflects the alleles in parents and their progeny (number reflects the progeny counted).

	Parents		75	Progeny		
	P1	P2		80	22	16
A	—	—	—	—	—	—
a	—	—	—	—	—	—
B	—	—	—	—	—	—
b	—	—	—	—	—	—

Which one of the following statements correctly explains the band pattern?

1. In the heterozygous parent, the alleles are in coupling configuration.
2. In the heterozygous parent, the alleles are in repulsion configuration.
3. The alleles A and B are in different linkage groups.
4. The information is insufficient for any conclusion.

22. Given below are terms related to various experimental techniques (Column X) and their applications (Column Y):

Column X	Column Y
Technique	Application
A. Mass Spectrometry	i. Separation of whole chromosomes
B. Pulsed Field Gel Electrophoresis	ii. Separation of isoenzymes
C. Isoelectric Focusing	iii. Single-molecule-real-time sequencing
D. PacBio	iv. Identification of post-translational modifications of proteins

Which one of the following options represents all correct matches between Column X and Column Y?

1. A-iv, B-i, C-ii, D-iii
2. A-iii, B-iv, C-i, D-ii
3. A-ii, B-iii, C-iv, D-i
4. A-iv, B-iii, C-i, D-ii

23. The relationship between species and area of distribution is given by the following equation:  $S = CA^z$  where  $S$  is the number of species on an island or isolated patch,  $A$  is the area of the habitat, and  $C$  and  $Z$  are constants. The following are a set of statements pertaining to the value of 'Z':

- A.  $Z$  value is typically not greater than 0.4 across all ecosystem types.
- B.  $Z$  value is positively related to a species' dispersal capability, with flying and wind-dispersed organisms having the highest values.
- C.  $Z$  value, which represents the slope in the relationship, declines with area, especially when large landmasses such as continents are considered.
- D. The  $Z$  value is the exponent in the power model and can be used to estimate the proportion of area required to represent a given proportion of species present in any land class.

Select the option that represents the combination of all correct statements.

1. A and B
2. A and D
3. B and C



The following statements are made in this regard:

- A. GLABRA1 (GL1) mutant plant will show fewer or no trichomes.
- B. Cells that form trichomes strongly express the GLABRA2 (GL2) and TRYPTICON (TRY) genes.
- C. TRY protein acts as a positive regulator of trichome cell differentiation in the surrounding cells.
- D. Addition of exogenous JA will reduce the number of leaf trichomes.

Which one of the following options represents the combination of all correct statements?

- 1. A and B
- 2. B and C
- 3. C and D
- 4. A and D

27. Following statements are made regarding the roles of complement components in immunity:

- A. Binding of complement components to antigen presenting cells decreases their phagocytic ability and modulates cytokine secretion.
- B. Complement components enhance the B cell-mediated immune response by increasing the avidity with which a B cell binds to a complement-bound antigen.
- C. Immature T cells are protected from the natural antibody and complement-mediated lysis by provision of additional sialic acid residues on their cell surface glycoproteins.
- D. Binding of C3a, C5a and C3b to their respective receptors on mature T cells inhibits their growth, differentiation, and survival.
- E. During the contraction phase of the immune response, excess lymphocytes that were made during antigen-induced expansion are eliminated by apoptosis, with the help of C1q complement component.

Which of the following options represents the combination of all correct statements:

- 1. A, B and C
- 2. A, C and D
- 3. B, C and E
- 4. B, D and E

28. In the context of signaling, the enzyme protein kinase C (PKC) depends on multiple molecules for its complete activation. This activation depends on the presence of:

- A. phosphatidylserine at the inner leaflet of the plasma membrane.
- B.  $Ca^{2+}$
- C. phosphatidylethanolamine at the inner leaflet of the plasma membrane.
- D. diacylglycerol present in the inner leaflet of the plasma membrane.

Which one of the following options represents the combination of all correct molecules?

- 1. A, B and C
- 2. A, C and D
- 3. B, C and D
- 4. A, B and D

29. Aspartate (Asp) is an amino acid with the structure  $NH_2 - CH(CH_2 - COOH) - COOH$ . Given below are biosynthetic processes occurring in cells:

- A. protein synthesis
- B. de novo synthesis of inosine monophosphate and orotic acid
- C. synthesis of adenosine monophosphate from inosine monophosphate
- D. glutathione synthesis

Which one of the following options correctly represents all the biosynthetic process(es) wherein Asp is involved as a precursor?

- 1. A only
- 2. A, C and D
- 3. A and C only
- 4. A, B and C

30. Bacteriophage  $\lambda$  and P1 are both temperate phages. Which one of the following statements made about these phages and their lytic and lysogeny cycles in *E. coli* is INCORRECT?

- 1. Both the  $\lambda$  and P1 phages are double stranded DNA viruses.
- 2. In their lysogenic states in *E. coli*, while the  $\lambda$  phage integrates into the genome, the P1 phage remains as a low copy number plasmid.
- 3. In their lysogenic states, both the  $\lambda$  and the P1 phages are integrated into the genome in *E. coli*.
- 4. In their lytic cycles, both the phages occur in plasmid forms in *E. coli*.

31. The following table depicts the digital numbers of 12 pixels in two different bands (indicated below each pixel group) of an image collected from the LISS- IV sensor of Resourcesat1 satellite.

222	210	190
125	98	100
127	109	95
95	98	90

200	195	192
115	185	195
128	111	192
87	90	92

620-680 nm      770-860 nm

Which one of the following options represents the correct identification of only vegetated (darkened) pixels?

1.

2.

3.

4.



32. Different types of mapping populations that can be created using a variety of methods are presented as I to IV in the figure below:

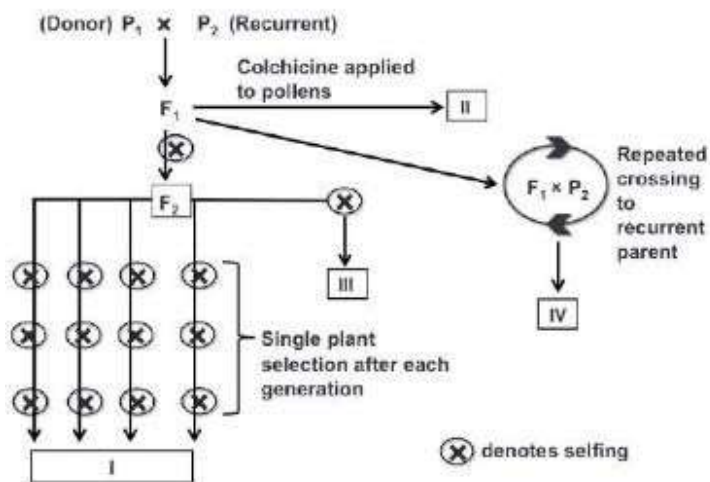

A list of probable mapping populations denoted by I to IV in the figure and their status of genetic mortality is given below.

- A. I - Recombinant inbred lines (RILS) - immortal
- B. II - Doubled haploid - Not immortal
- C. III  $F_{2:3}$  Not immortal
- D. IV - Near isogenic Lines (NILs) - immortal

Which one of the following options represents the combination of all correct matches?

- 1. C only
- 2. A and D only
- 3. B and C only
- 4. A, C and D

33. Following statements are about the features of immunoassays used to assay biomolecules:

- A. Radio-immunoassays (RIAS) are more sensitive than Enzyme-linked immunosorbent assays (ELISAs) with chromogenic substrates.
- B. ELISAs with chromogenic substrates are more sensitive than ELISAs with chemiluminogenic substrates.
- C. ELISPOT measures the number of cells capable of secreting particular biomolecules using a substrate that gives soluble product with enzyme reaction.
- D. In Western blot analysis, the product of enzyme-substrate reaction localises at the site precisely where the antibody-enzyme conjugate binds to its specific protein band.

Which of the following options represents the combination of all correct statements:

- 1. A and C
- 2. A and D
- 3. B and C
- 4. B and D

34. Mass spectrum of a pure peptide recorded in the positive ion mode is shown below.

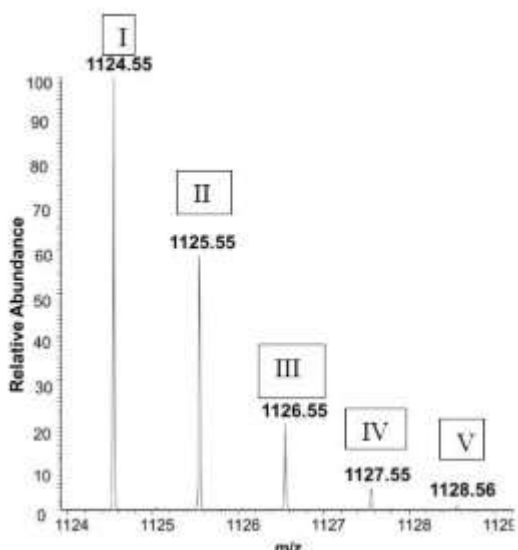

(A) What is the reason for multiple peaks in the mass spectrum of a pure peptide? (B) Which peak corresponds to the monoisotopic species of the peptide? (C) What is the monoisotopic mass of the peptide? Select the right answers from the options given below.

- (A)  $^{13}\text{C}$  isotope distribution, (B) peak V and (C) 1128.56 Da
- (A)  $^{14}\text{C}$  isotope distribution, (B) peak I and (C) 1124.55 Da
- (A)  $^{13}\text{C}$  isotope distribution, (B) peak I and (C) 1124.55 Da
- (A)  $^{14}\text{C}$  isotope distribution, (B) peak V and (C) 1128.56 Da

35. Given below are a few terms related to Bioinformatics resources (Column X) and their functions/applications (Column Y):

	Column x		Column Y
	Resources		Functions/applications
A.	TREMBL	i.	Analysis of recombination frequencies between molecular markers
B.	TBLASTN	ii.	Database of protein sequences
C.	SCOP	iii.	Comparison of amino acid sequence against nucleotide sequence data-base translated in all six reading frames
D.	JoinMap	iv.	Manually curated structural classification of proteins

Which one of the following options represents all correct matches between Column X and Column Y?

- A-ii, B-iii, C- iv, D-i
- A-iv, B-i, C-ii, D-iii
- A - iii, B-i, C - iv, D-ii
- A- iv, B-iii, C-ii, D-i

36. The recognized family of PR proteins in plants and their activities are listed in columns X and Y, respectively.

	Column x		Column Y
	Proteins		Activities
A.	PR2	i.	$\beta$ -1,3-glucanase
B.	PR3	ii.	chitinase
C.	PR6	iii.	proteinase inhibitor
D.	PR10	iv.	ribonuclease-like

Which one of the following options represents all correct matches between Column X and Column Y?

1. A-i, B-iii, C-iv, D-ii
2. A-i, B-ii, C-iii, D-iv
3. A-iii, B-iv, C-i, D-ii
4. A-iv, B-i, C-ii, D-iii

37. Red-blue colour blindness is a human X-linked recessive disorder. The two parents with normal colour vision have two sons. Son 1 has 47, XXY chromosome composition and is colour blind. Son 2 has 46, XY and is also colour blind. Assuming that no crossing over took place in prophase I of meiosis, Klinefelter syndrome in Son 1 resulted due to nondisjunction during which one of the following events?

1. Female gamete formation in meiosis I
2. Female gamete formation in meiosis II
3. Male gamete formation in meiosis I
4. Male gamete formation in meiosis II

38. It has been observed that within a flowering season, a plant may produce more male flowers which may be correlated with the longevity of the flowers and the seasonal distribution of flowering in the plant. Which one of the following arguments do NOT support this observation of sex-specific floral phenology.

1. Females are often resource limited and therefore pollination levels will be increased by producing more male flowers.
2. Fluctuations in the rainfall pattern can influence pollinator service due to altered physiology of the plant during its reproduction, leading to a shift in flowering phenology of both sexes.
3. Plasticity in sex and their flowering phenology is determined neither by resource status of a taxon nor by fluctuations in climatic factors.
4. Male competition will favour floral features that improve pollinator visits and therefore more male flowers.

39. Amborellaceae, Aristolochiaceae, Illiciaceae and Winteraceae are four angiosperm families that, according to the APG IV system of classification belong to the 'early diverging angiosperms'. The presence (V+) or absence (V-) of vessels in the xylem and the fusion of the carpels within the gynoecium are important angiosperm characters. 'A' and 'S' indicate apocarpous (or monocarpellary) and syncarpous condition of ovary, respectively. Which one of the following options correctly represents the characters found in the above families?

1. Amborellaceae: V+, A; Aristolochiaceae: V+, A; Illiciaceae: V+, A; Winteraceae: V-, S.
2. Amborellaceae: V-, A; Aristolochiaceae: V+, S; Illiciaceae: V+, A; Winteraceae: V-, A.
3. Amborellaceae: V-, S; Aristolochiaceae: V-, S; Illiciaceae: V+, S; Winteraceae: V+, A.

4. Amborellaceae: V+, S; Aristolochiaceae: V-, A; Illiciaceae: V+, S; Win- teraceae: V-, S.

40. In eukaryotes, microtubules and actin-binding proteins influence the dynamics and organization of the cytoskeleton. Match the cytoskeleton-binding proteins listed in column B, to actin or microtubule mentioned in Column A, and their function from those listed in Column C.

Column A	Column B	Column C
X. microtubule	(i) ketenin	(a) filament cross-linking
Y. actin	(ii) tropomodulin	(b) severs filaments and binds to plus end
	(iii) tau	(c) prevents assembly and disassembly at minus end
	(iv) gelsolin	(d) only severs filament

Which one of the following options represents all the correct matches between columns A, B and C?

1. X-(iv)-(c), X-(iii)-(b), Y-(i)-(a), Y-(ii)-(d)
2. X-(ii)-(a), X-(i)-(c), Y-(iv)-(c), Y-(iii)-(b)
3. X-(iii)-(a), X-(i)-(d), Y-(ii)-(c), Y-(iv)-(b)
4. X-(i)-(d), X-(iv)-(a), Y-(iii)-(d), Y-(ii)-(c)

41. The following statements were made about cell cycle regulation in fission yeast:

- A. A cdc25 mutant cannot enter mitosis due to its inability to remove the inhibitory phosphate.
- B. Weel consistently maintains the Cdk in an active state, to maintain cell size during cell cycle.
- C. CAK (Cdk-activating kinase)-mediated phosphorylation of Threonine 161 residue of Cdc2 is necessary, but not sufficient, for the Cdk to be active.
- D. Activation of Sic1 in G1 allows the cyclin-Cdk that is present in the cell to initiate DNA replication.
- E. sic1 mutant exhibits activation of premature DNA replication from fewer origins and extension of the duration of S phase.

Which one of the following options represents the combination of all correct statements?

1. A, B and D
2. A, C and E
3. B, D and E
4. A, C and D

42. The following statements are made about digestion of proteins and the enzymes involved:

- A. Chymotrypsin does not generate peptides with C-terminal neutral amino acids.
- B. Trypsin generates peptides with C-terminal basic amino acids.
- C. Carboxypeptidase B acts on aromatic amino acids.
- D. Carboxypeptidase A employs zinc ion for hydrolysis.
- E. The brush border enterokinase has no polysaccharides attached to it.
- F. The final digestion to amino acids occurs in the intestinal lumen, the brush border, and the cytoplasm of the mucosal cells.

Which one of the following options represents the combination of all correct statements?

1. A, B and C
2. C, D and E

3. D, E and F
4. B, D and F

43. ERK5 is a MAP kinase that is activated upon phosphorylation by MEK5. MEK5 binds with MEKK2 when co-expressed. HEK293 cells were transfected with plasmid encoding ERK5, along with plasmids encoding either MEK5 alone, or MEKK2 alone, or both MEKK2 and MEK5, or both MEKK2 and MEK5AA (MEK5 mutant). Lysates of transfected cells were analysed by Western blotting using anti-ERK5 antibody as shown below:

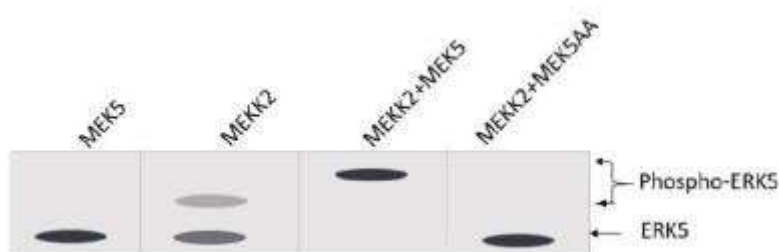

From the data in the figure above, the following conclusions were drawn:

- A. Full activation of ERK5 requires both MEKK2 and MEK5.
- B. Phosphorylation with MEKK2 alone suggests that it can activate ERK5 without MEK5.
- C. Difference in the levels of phosphorylation with MEKK2 alone and MEKK2 + MEK5 is due to more phosphorylation at the same site.
- D. Phosphorylation with only MEKK2 transfection suggests that it might be associating with endogenous MEK5 to get partially activated, leading to ERK5 phosphorylation to some extent.
- E. MEK5AA might be a dominant-negative mutant of MEK5 which prevents signalling through active, endogenous MEK5.

Which of the following options represents the combination of all correct statements?

1. A, B and C
2. B, C and E
3. C, D and E
4. A, D and E

44. Following statements are made regarding the plant natural product, terpenes.

- A. Monoterpenes are five-carbon compounds.
- B. The anti-malarial drug, artemisinin is a sesquiterpene.
- C. Azadirachtin is a triterpene derivative from the seed oil of the Asian neem tree.
- D. Taxol is a diterpene derivative used in cancer treatment.

Which one of the following options represents the combination of all correct statements?

1. A and B only
2. C and D only
3. A, B and D
4. B, C and D



4. A-Regular and B-Regular

47. Given below are a set of statements about metapopulation dynamics and habitat conservation:

- A. The sizes of suitable patches are important because demographic stochasticity can lead to extinction, especially in organisms with low reproductive output.
- B. In the incidence function model (IFM), the extinction risk of local populations increases with increasing habitat patch area, and the colonization probability is a function of patch isolation from existing local populations.
- C. From the conservation perspective, large numbers of suitable patches are not sufficient if distances are too large, preventing recolonization and the rescue effect.
- D. To minimize extinction risk there should be as low a variance in local patch quality as possible, to allow for synchronous dynamics.

Which one of the following options represents the combination of all correct statements?

- 1. A and C
- 2. B and C
- 3. A and D
- 4. B and D

48. A transgenic plant having a homozygous single-copy insertion for trait A was re-transformed by Agrobacterium-mediated transformation with a gene conferring trait B. Given below are a few statements regarding the above experiment:

- A. All  $T_0$  transgenic plants obtained after re-transformation would be single copy events for both traits, A and B.
- B.  $T_1$  progeny generated by self-pollination of single-copy transgenic plants obtained by retransformation would segregate in a 3:1 ratio for trait A.
- C. Plant selection marker genes used for transformation experiments for both traits, A and B should be necessarily identical. Different selection marker genes cannot be used.
- D. 25% of  $T_1$  progeny generated by self-pollination of single-copy transgenic plants obtained by retransformation would be homozygous for both traits, A and B.

Which one of the following options represents all INCORRECT statements?

- 1. A, C and D
- 2. A, B and C
- 3. D only
- 4. A and C only

49. Following statements are made regarding animal development:

- A. The cell is first specified towards a given fate, suggesting that it would develop into this cell type, even in a neutral environment.
- B. Holoblastic rotational cleavage is observed in tunicates.
- C. Infolding of sheet of cells is called ingression.
- D. Conditional specification can be observed in sea urchin embryos.

Which one of the following options represents the combination of all correct statements?



1. A and B
2. B and C
3. A and D
4. C and D

50. 100  $\mu\text{L}$  of cells were taken in a tube and 400  $\mu\text{L}$  0.4% Trypan Blue was added for staining. About 20  $\mu\text{L}$  of this cell suspension was added between the hemocytometer and cover glass (refer figure below). The hemocytometer is divided into 9 major squares of 1 mm x 1 mm size. The height of the chamber formed with the cover glass is 0.1 mm. Empty circles indicate unstained cells and solid circles indicate stained cells.

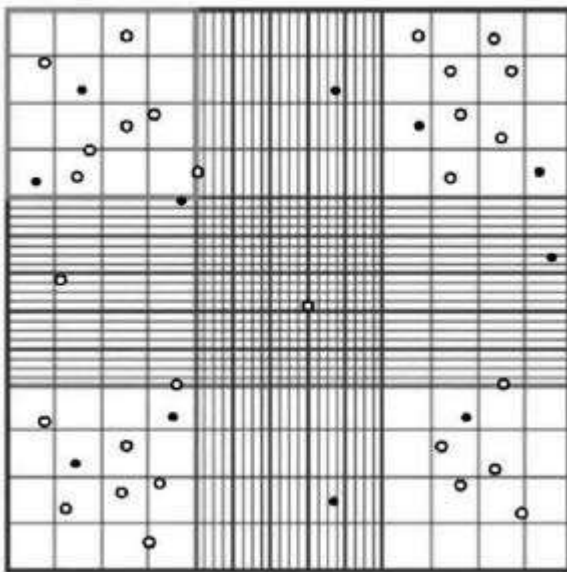

Based on the above figure, what is the total cell count in the original suspension and cell viability (%)?

1. 3,75,000 cells/mL and 23%
2. 3,75,000 cells/mL and 77%
3. 18,75,000 cells/mL and 77%
4. 75,000 cells/mL and 23%

51. Based on the theory of kin selection, choose the correct statement:

1. A gene for altruism will spread in the population if the act of altruism increases the actor's gene in the next gene pool only through direct fitness.
2. A gene for altruism will spread in the population if the act of altruism increases the actor's gene in the next gene pool only through indirect fitness.
3. A gene for altruism will spread in the population if the act of altruism increases the actor's gene in the next gene pool through direct or indirect fitness.
4. Altruistic behaviour reduces the fitness of the trait bearer so a gene responsible for altruism cannot spread in a population and will be maintained at a very low frequency.

52. A researcher isolated chromatin from mammalian cells and digested with micrococcal nuclease in different tubes for 1 h, 3 h, 6 h, and 12 h. Thereafter, DNA was purified from all the digested chromatin samples, and two independent Southern blot hybridization experiments were performed with probe-



I and probe- II. The probe-I and probe-II correspond to different loci of the chromosome(s). The images below represent the Southern blot hybridization pattern generated by probe-I and probe-II.

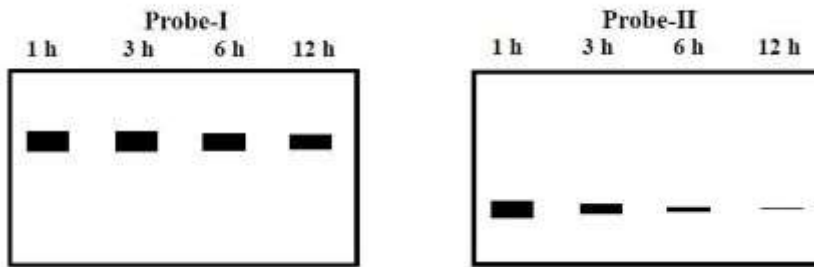

Following statements were made to explain the results of the Southern blot experiments.

- A. Size of probe-II is smaller than probe-I.
- B. Probe-I may correspond to the centromeric region of the chromosome.
- C. Probe-I may correspond to a hypomethylated locus of the genome.
- D. Probe-II may correspond to an euchromatic locus of the genome.

Which one of the following options represents the combination of all correct statements?

- 1. A and C
- 2. B and D
- 3. A only
- 4. B only

53. Which one of the following statements pertaining to global ocean ecosystem productivity is NOT correct?

- 1. Higher chlorophyll concentrations and the general higher productivity observed around the equator is driven by the process of upwelling and/or mixing of high nutrient subsurface water into the euphotic zone.
- 2. In some temperate and subpolar regions, productivity is least during the spring due to the transitioning of phytoplankton from light-limiting to nutrient-limiting conditions.
- 3. In the nutrient-poor tropical and subtropical ocean, the cyanobacteria tend to be numerically dominant, as they specialize in taking up nutrients at low concentrations.
- 4. Larger phytoplankton, such as diatoms, often dominate the nutrient-rich polar ocean, and these can be grazed directly by multicellular zooplankton.

54. Assume that the genes  $w^+$  and  $cv^+$  are located 20 cM apart on the X chromosome of *Drosophila melanogaster*. Mutations in  $w^+$  and  $cv^+$  give rise to white eyes and crossveinless phenotypes, respectively, which are recessive to the wild-type phenotype. A homozygous wild-type female was crossed to a white-eyed, crossveinless male. The  $F_1$  progeny was sib-mated. What percentage of the progeny will be white-eyed and crossveinless?

- 1. 20
- 2. 40
- C. 10
- 4. 5

55. Some properties of enzymes are listed in column X, and their kinetic expressions are listed in column Y.

	Column X		Column Y
	Enzyme properties		Expressions
A.	Specific activity	i.	$k_{cat}/K_m$
B.	Turnover number	ii.	substrate concentration at which $v = (V_{max})/2$
C.	Michaelis constant	iii.	$V_{max}/\text{moles of enzyme}$
D.	Catalytic efficiency	iv.	$V_{max}/\text{protein concentration}$

Which one of the following options represents all correct matches between Column X and Column Y?

1. A- ii, B-i, C - iii, D-iv
2. A-iii, B-ii, C- iv, D-i
3. A iv, B-iii, C - ii, D-i
4. A-i, B - iv, C - ii, D-iii

56. The diagram below depicts the cumulative fossil CO<sub>2</sub> emissions (y axis) of different continents from the years 1850-2020 (x axis).

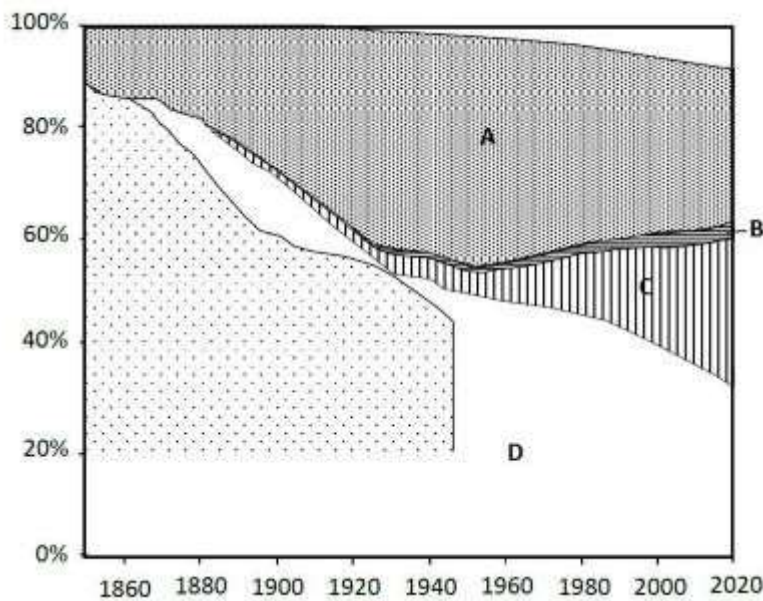

Select the option that correctly identifies the continents A-D:

1. A-North America; B-Africa; C-Asia; D-Europe
2. A-Europe; B-South America; C-Africa; D-Asia
3. A-Europe; B-Africa; C-North America; D-Asia
4. A-North America; B-Asia; C-Africa; D-Europe

57. The following statements were made about the structure of the 30-nm chromatin fiber:

- A. In the solenoid model, the linker DNA connects the consecutive core particles.
- B. In the zig-zag model, alternating nucleosomes become interacting neighbors.
- C. In the solenoid model, 12 nucleosomes are organized into two separate stacks, whereas 8 nucleosomes per turn make a single stack in the zig-zag model.
- D. H1 histone is essentially required as per the zig-zag model, but not as per the solenoid model.

E. Chromatin fibers prepared with H4 histones that lack their tails could fold into higher-order fibers.

Which one of the following options represents the combination of all correct statements?

1. A, C and D
2. A, B and E
3. A and B only
4. C and E only

58. Match the eukaryotic cellular organelles listed in Column X with their typical function from among those listed in Column Y.

	Column X		Column Y
	Organelles		Function
A.	Golgi	i.	Ribosomes assembly
B.	Nucleolus	ii.	O-linked Glycosylation
C.	Peroxisomes	iii.	Site for lipid synthesis
D.	ER	iv.	Oxygen utilization

Which one of the following options represents all correct matches between Column X and Column Y?

1. A-(iii), B-(iv), C-(ii), D-(i)
2. A-(ii), B-(i), C-(iv), D-(iii)
3. A-(ii), B-(iii), C-(i), D-(iv)
4. A-(iii), B-(i), C-(iv), D-(ii)

59. The following figure represents the interaction between different blastomeres in a 4-cell stage of *C. elegans* embryo:

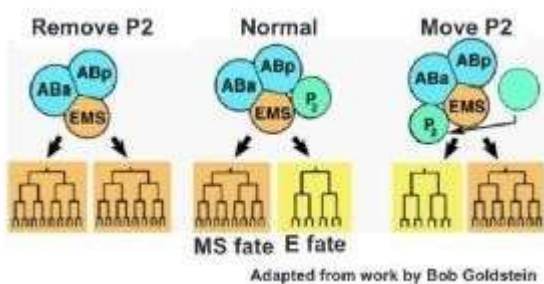

The following statements were made regarding the above:

- A. The fate of EMS blastomere is autonomously specified.
- B. The default fate of EMS blastomere is MS cell lineage.
- C. Conditional specification can be observed in the development of E cell lineage.
- D. Assuming that a receptor needs to be activated for E fate, a *C. elegans* embryo where the receptor is constitutively active, is likely to develop cells of E fate only, in all three of the above cases.

Which one of the following options represents the combination of all correct statements?

1. A and C only
2. B and C only
3. A, B and C

4. B, C and D

60. The following list represents two types of reproductive isolation (Column P) that can lead to speciation. Column Q represents the processes by which these isolations can occur.

Column P	Column Q	
A - Prezygotic	i.	Seasonal
B- Postzygotic	ii.	Hybrid inviability
	iii.	F <sub>2</sub> breakdown
	iv.	Stigmatic SI response

Select the option that represents the correct match between the prezygotic and postzygotic isolation types listed in Column P and the processes described in Column Q?

1. A-i and ii, B-i and iii
2. A-i and iii, B- ii only
3. A-i and iv, B-ii and iii
4. A- ii only, B-i and iv

61. Rubisco enzyme is involved in both reductive and oxidative carbon cycles in plants. Following are certain statements regarding them:

- A. Sugars are produced in both the cycles.
- B. Ferredoxin is reduced only in oxidative carbon cycle.
- C. Product of oxidative cycle is one of the substrates of reductive cycle.
- D. NADP and ATP are used in both the cycles.

Which one of the following options represents the combination of all correct statements?

1. A and B
2. A and D
3. C and D
4. B and C

62. The following statements refer to factors regulating the fidelity of DNA replication.

- A. The 5' to 3' exonuclease activity of the replicative DNA polymerase.
- B. Imbalanced intracellular concentrations of the four dNTPs.
- C. Increased intracellular concentrations of INTPs resulting in increased incorporation of rNTPs during DNA synthesis, which are not easily removed by the polymerase's proof-reading activity.
- D. Removal of incorrectly incorporated nucleotides by the mismatch repair system.

Which one of the following options gives the combination of all correct statements?

1. A and D only
2. B, C and D
3. B and C only
4. A, B and D

63. The following are certain statements regarding the PSII electron carrier during the light reaction of photosynthesis:

- A. The first electron released from reaction centre P680 is transferred to  $Q_A$  to produce a plastoquinone.
- B.  $Q_A$  is the mobile plastoquinone.
- C. The first electron transferred from  $Q_A$  to  $Q_B$  converts  $Q_B$  into plastoquinone.
- D.  $Q_B$  is tightly bound to the complex and is not mobile.

Which one of the following options represents the correct statement(s)?

1. A and B
2. B and D
3. A only
4. C only

64. The  $\text{LacI}$  and  $\text{TrpR}$  repressors bind with their ligands allolactose and tryptophan respectively, resulting in alteration of their DNA binding properties. The following statements are made about the mechanism of  $\text{LacI}$  and  $\text{TrpR}$  binding with DNA (operator) and regulation of gene expression in *E. coli*.

- A. Allolactose binding to  $\text{LacI}$  leads to its poor binding to the  $\text{lac}$  operator whereas tryptophan binding to  $\text{TrpR}$  leads to its better binding to the  $\text{trp}$  operator.
- B. Allolactose binding to  $\text{LacI}$  leads to induction of  $\text{lac}$  operon, whereas tryptophan binding to  $\text{TrpR}$  leads to repression of  $\text{trp}$  operon.
- C. Binding of allolactose and tryptophan to  $\text{LacI}$  and  $\text{TrpR}$  respectively, leads to repression of their corresponding operons.
- D. Binding of allolactose and tryptophan to  $\text{LacI}$  and  $\text{TrpR}$  respectively, leads to activation of their corresponding operons. However, in  $\text{trp}$  operon regulation, availability of tryptophan also results in attenuation-mediated transcriptional termination leading to an overall effect of repression of  $\text{trp}$  operon.

Which one of the following options represents a combination of all correct statements?

1. A and B only
2. B and C
3. C and D
4. A, B and D

65. A researcher wanted to test the effect of different chemical agents on double stranded DNA (dsDNA). dsDNA was taken in tubes (A, B, C and D), and four different agents were added individually to each tube. The researcher however forgot to label them. The properties of the added chemical agents on dsDNA were analysed. The possible product (Column X) and the specific action of the chemical agents are listed in Column Y.

	Column X		Column Y
A.	Nucleotides	i.	Breaks hydrogen bond
B.	Only nitrogenous bases	ii.	Removes phosphate group
C.	Nucleosides	iii.	Breaks phosphodiester bond
D.	ssDNA	iv.	Breaks N-glycosidic bond

Which one of the following options represents all correct matches between Column X and Column Y?

1. A-ii, B-i, C-iv, D-iii
2. A-iii, B-iv, C-ii, D-i
3. A-iv, B-iii, C-i, D-ii
4. A-iii, B-ii, C-iv, D-i

66. The following statements are made below about hearing phenomena of sound waves:

- A. The loudness of a sound is inversely correlated with the amplitude of a sound wave.
- B. The loudness of a sound is directly correlated with the amplitude of a sound wave.
- C. The pitch of a sound is directly correlated with the frequency of the sound wave.
- D. The pitch of a sound is inversely correlated with the frequency of the sound wave.
- E. The pitch of the average male voice in conversation is lower than that of the average female voice.
- F. The pitch of the average male voice in conversation is higher than that of the average female voice.

Choose the combination of all correct statements:

- 1. A, C and E
- 2. B, D and F
- 3. B, C and E
- 4. A, D and F

67. The following statements suggest the changes in respiratory ventilation and the mechanisms of these changes when a normal human subject is allowed to inhale air containing different oxygen content:

A. The ventilation is markedly increased when  $P_{O_2}$  of the inspired air is less than 60 mm Hg.

B. The ventilation is 6 L/min when the  $P_{O_2}$  of the inspired air is about 150 mm Hg.

The ventilation is slightly increased when  $P_{O_2}$  of the inspired air is more than 60 mm Hg.

The increased ventilation due to the lower  $P_{O_2}$  in the inspired air causes higher alveolar  $P_{CO_2}$ .

The  $H^+$  concentration in the arterial blood is increased when  $P_{O_2}$  of the inspired air is gradually decreased.

Which one of the following options represents the combination of all correct statements?

- 1. A, B and C
- 2. B, C and D
- 3. C, D and E
- 4. A, B, and E

68. The following statements are made about telomeres:

A. Telomere-binding proteins (TBPs) are believed to shield telomeres from the cell's DNA repair machinery, preventing them from being recognized as double-strand breaks.

B. Telomeres in human cells are repeats of TTAGGGG sequence that can extend upto 150 kb, which are replicated by the action of TERT in actively dividing cells.

C. In differentiated cells, telomerase is inactive, leading to shortening of telomeres over hundreds of cell divisions, damage to ends of chromosomes, and eventually apoptosis.

D. The persistence of telomerase activity in several cancers allows the cells to continue to proliferate.

Which one of the following options represents the combination of all correct statements?

- 1. A and C only
- 2. A, B and C
- 3. B and D only
- 4. A, C and D

69. A scientist is using the Hardy-Weinberg equation to assess if a population is in equilibrium or is evolving. She recorded the following characteristics for this population:

- A. The size of the population is very large.
- B. Individuals are randomly mating.
- C. Individuals are under natural selection.
- D. New alleles are added to the population through migration and dispersal.
- E. Mutation rates are high.

Which one of the following options contains all INCORRECT characteristics of a population in Hardy-Weinberg equilibrium?

- 1. A and D
- 2. C, D and E
- 3. A, B and C
- 4. B and E

70. Prolactin is an anterior pituitary hormone which is lactogenic and helps milk production in mammals. The statements below are made regarding the mechanism of action of prolactin:

- A. The receptors that bind to prolactin lack intrinsic tyrosine kinase activity.
- B. Upon prolactin binding, the receptors dimerize, and associated kinase is activated.
- C. Prolactin binding to receptors leads to activation of its intrinsic kinase activity.
- D. STAT plays a role in mediating prolactin action. It dimerizes after its phosphorylation to elicit the response.
- E. There is no involvement of STAT in prolactin action mechanisms.

Which one of the following options represents the combination of all correct statements?

- 1. A, B and D
- 2. B, C and D
- 3. A and E only
- 4. C and E only

71. Consumption of untreated corn as the staple food causes the disease, pellagra. Pre-treatment of corn with Ca(OH), prevents this disease. Given below are options listing possible effects of Ca(OH), treatment (Column X) and the enzymes affected (Column Y).

	Column X		Column Y
	Possible effects of Ca(OH) <sub>2</sub> treatment		Enzyme/s affected
A.	Release of Vitamin B3 upon Ca(OH) <sub>2</sub> treatment	i.	Activity of trypsin
B.	Alkaline pH aids in digestion.	ii.	Enzymes of the TCA cycle
C.	Ca improves bone strength	iii.	Activity of NAD-de pendent dehydrogenases
D.	Prevents formation of ROS	iv.	Activity of cathepsin K

Select the correct match relevant for preventing pellagra from the options listed below.

- 1. C-iv
- 2. B-i
- 3. A-iii
- 4. D-ii



72. After severe diarrhoea, the plasma  $K^+$  concentration became low (i.e, hypokalemia developed) in a human subject. The following statements are proposed to explain the mechanism of plasma  $K^+$  regulation by kidney in this condition:

- A. The principal cells present in distal tubule and collecting duct of nephron regulate  $K^+$  excretion.
- B. Hypokalemia stimulates  $Na^+$ ,  $K^+$  -ATPase activity in the basolateral membrane of principal cells.
- C. The intracellular  $K^+$  concentration of the principal cells is increased. D. The electrochemical gradient for efflux of  $K^+$  across the apical membrane of principal cells is increased.
- E. The permeability of apical membrane to  $K^+$  is decreased.
- F. The plasma aldosterone level is decreased which inhibits  $K^+$  secretion by principal cells.

Which one of the following options represents the combination of all INCORRECT statements?

- 1. A, B, C
- 2. B, C, D
- 3. C, D, E
- 4. D, E, F

73. The following statements were made about phase contrast microscopy.

- A. Phase contrast microscopy can be equally utilized to examine stained and unstained specimens.
- B. A phase annulus generates hollow cone of light to illuminate the specimen.
- C. A light wave that passes through a cell nucleus and organelles lags compared to the light waves that pass through water only.
- D. A polarized light source is used to translate the minor phase shifts into grey values.
- E. Appearance of bright halos is a common artifact of phase contrast imaging.

Which one of the following options represents the combination of all correct statements?

- 1. A, C and D
- 2. B, C and E
- 3. A, B and C
- 4. B, D and E

74. Transforming the neural plate into a neural tube is an important event towards the formation of central nervous system, in which the following sub-events might take place:

- A. In primary neurulation, the cells surrounding the neural plate direct the neural plate cells to proliferate, invaginate and separate from the surface ectoderm to form a hollow tube.
- B. In secondary neurulation, the neural tube does not arise from the aggregation of mesenchyme cells into a solid cord.
- C. The morphogen, Sonic hedgehog, that is expressed in notochord, is required for induction of floor plate cells in the neural plate to form the medial hinge point.
- D. In mammals, secondary neurulation begins at the level of sacral vertebrae.
- E. In mammals, the primary neurulation forms brain regions while the secondary neurulation takes care of forming rest of the central nervous system from neck to tail.

Which one of the following options represents the combination of all correct statements?

- 1. A, C and D
- 2. A, B and E
- 3. B, C and D
- 4. C, D and E



75. The following patterns of gene expression were obtained after activating Notch1 receptor with two different ligands DII1, and DII4.

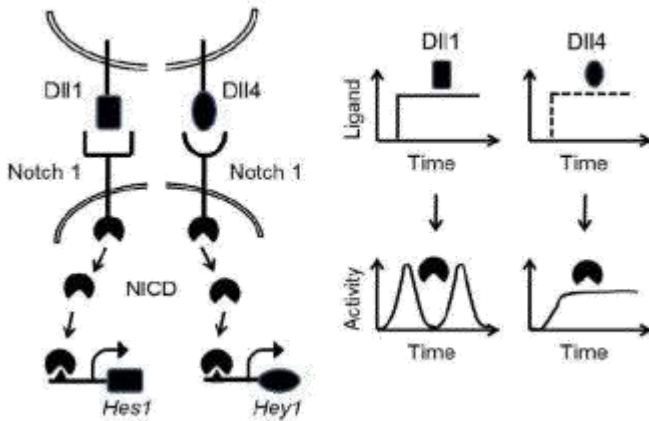

Which one of the following statements depicts the correct interpretation of observations?

1. The Notch pathway ligands DIII and D114 both bind to the Notch1 receptor but activate different downstream effectors with similar dynamics.
2. DII1 induces sustained responses, which preferentially activate the transcriptional target Hes1.
3. DI14 induces pulsatile responses in response to NICD, which are required for activating Heyl.
4. The Notch pathway ligands DII1 and D114 both bind to the Notch1 receptor but activate the downstream effector NICD with different dynamics.